

## Small Signal Schottky Diodes

### Features

- Integrated protection ring against static discharge
- Low capacitance
- Low leakage current
- Low forward voltage drop
- Very low switching time
- AEC-Q101 qualified
- Compliant to RoHS directive 2002/95/EC and in accordance to WEEE 2002/96/EC
- Halogen-free according to IEC 61249-2-21 definition



**RoHS**  
COMPLIANT  
HALOGEN  
**FREE**

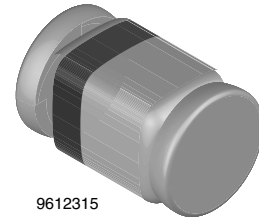

9612315

### Applications

- General purpose and switching Schottky barrier diode
- HF-Detector
- Protection circuit
- Diode for low currents with a low supply voltage
- Small battery charger
- Power supplies
- DC/DC converter for notebooks

### Mechanical Data

**Case:** MicroMELF

**Weight:** approx. 12 mg

**Cathode band color:** black

**Packaging codes/options:**

TR3/10 k per 13" reel (8 mm tape), 10 k/box

TR/2.5 k per 7" reel (8 mm tape), 12.5 k/box

### Parts Table

Part	Type differentiation	Ordering code	Remarks
BAS381	$V_R = 40\text{ V}$	BAS381-TR3 or BAS381-TR	Tape and Reel
BAS382	$V_R = 50\text{ V}$	BAS382-TR3 or BAS382-TR	Tape and Reel
BAS383	$V_R = 60\text{ V}$	BAS383-TR3 or BAS383-TR	Tape and Reel

### Absolute Maximum Ratings

$T_{amb} = 25\text{ }^\circ\text{C}$ , unless otherwise specified

Parameter	Test condition	Part	Symbol	Value	Unit
Reverse voltage		BAS381	$V_R$	40	V
		BAS382	$V_R$	50	V
		BAS383	$V_R$	60	V
Peak forward surge current	$t_p = 1\text{ s}$		$I_{FSM}$	500	mA
Repetitive peak forward current			$I_{FRM}$	150	mA
Forward continuous current			$I_F$	30	mA

## Thermal Characteristics

$T_{amb} = 25\text{ }^{\circ}\text{C}$ , unless otherwise specified

Parameter	Test condition	Symbol	Value	Unit
Junction to ambient air	on PC board 50 mm x 50 mm x 1.6 mm	$R_{thJA}$	320	K/W
Junction temperature		$T_j$	125	$^{\circ}\text{C}$
Storage temperature range		$T_{stg}$	- 65 to + 150	$^{\circ}\text{C}$

## Electrical Characteristics

$T_{amb} = 25\text{ }^{\circ}\text{C}$ , unless otherwise specified

Parameter	Test condition	Symbol	Min.	Typ.	Max.	Unit
Forward voltage	$I_F = 0.1\text{ mA}$	$V_F$			330	mV
	$I_F = 1\text{ mA}$	$V_F$			410	mV
	$I_F = 15\text{ mA}$	$V_F$			1000	mV
Reverse current	$V_R = V_{Rmax}$	$I_R$			200	nA
Diode capacitance	$V_R = 1\text{ V}$ , $f = 1\text{ MHz}$	$C_D$			1.6	pF

## Typical Characteristics

$T_{amb} = 25\text{ }^{\circ}\text{C}$ , unless otherwise specified

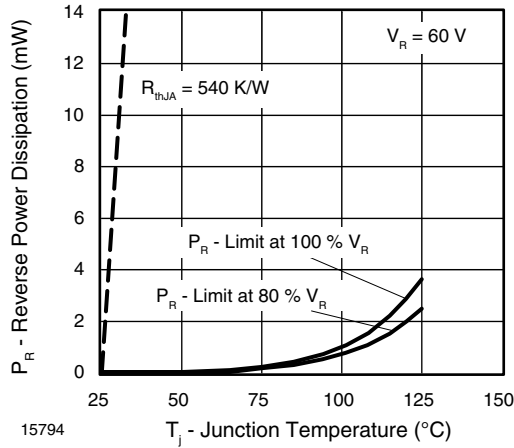

Figure 1. Max. Reverse Power Dissipation vs. Junction Temperature

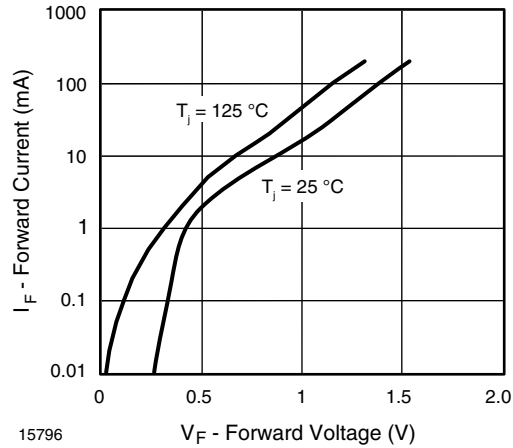

Figure 3. Forward Current vs. Forward Voltage

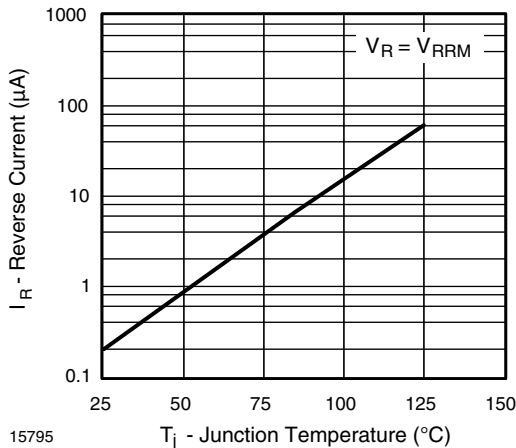

Figure 2. Reverse Current vs. Junction Temperature

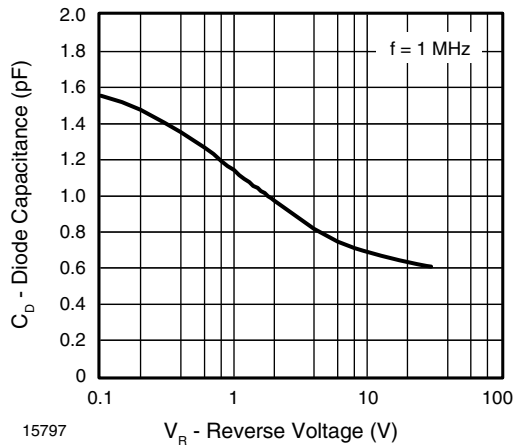

Figure 4. Diode Capacitance vs. Reverse Voltage

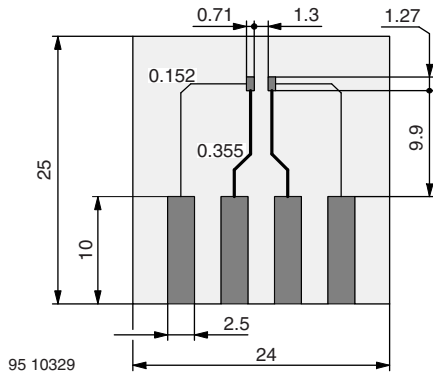
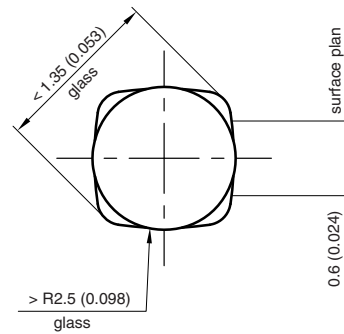
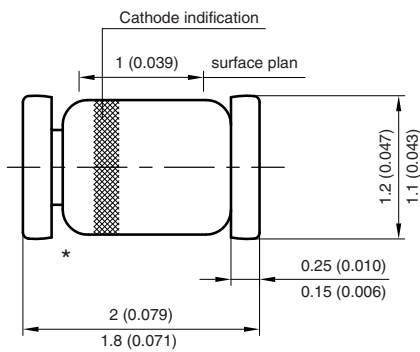

Figure 5. Board for  $R_{thJA}$  definition (in mm)

## Package Dimensions in millimeters (inches): MicroMELF



\* The gap between plug and glass can be either on cathode or anode side

Foot print recommendation:

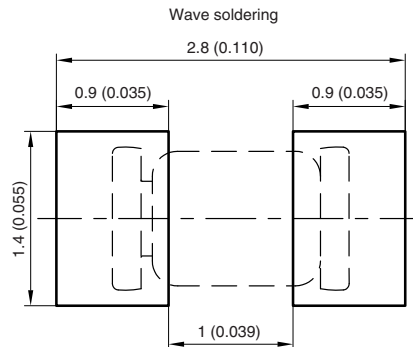
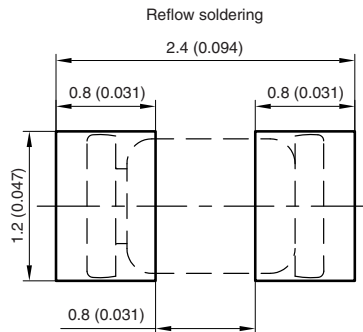

Created - Date: 26.July.1996  
 Rev. 13 - Date: 07.June.2006  
 Document no.: 6.560-5007.01-4  
 96 12072



## Disclaimer

All product specifications and data are subject to change without notice.

Vishay Intertechnology, Inc., its affiliates, agents, and employees, and all persons acting on its or their behalf (collectively, "Vishay"), disclaim any and all liability for any errors, inaccuracies or incompleteness contained herein or in any other disclosure relating to any product.

Vishay disclaims any and all liability arising out of the use or application of any product described herein or of any information provided herein to the maximum extent permitted by law. The product specifications do not expand or otherwise modify Vishay's terms and conditions of purchase, including but not limited to the warranty expressed therein, which apply to these products.

No license, express or implied, by estoppel or otherwise, to any intellectual property rights is granted by this document or by any conduct of Vishay.

The products shown herein are not designed for use in medical, life-saving, or life-sustaining applications unless otherwise expressly indicated. Customers using or selling Vishay products not expressly indicated for use in such applications do so entirely at their own risk and agree to fully indemnify Vishay for any damages arising or resulting from such use or sale. Please contact authorized Vishay personnel to obtain written terms and conditions regarding products designed for such applications.

Product names and markings noted herein may be trademarks of their respective owners.